

TOP OF WHEELHOUSE
2380 AB. EL.
BRIDGE DECK
2060 AB. EL.
UNDER BRIDGE DECK
1900 AB. EL.
C-DECK
1620 AB. EL.
B-DECK
1340 AB. EL.
A-DECK
1060/1060 AB. EL.
MAIN DECK
760/760 A. EL.
TWEEN DECK
VARIOUS
TANK TOP
1000/1000 AB. EL.
BASELINE

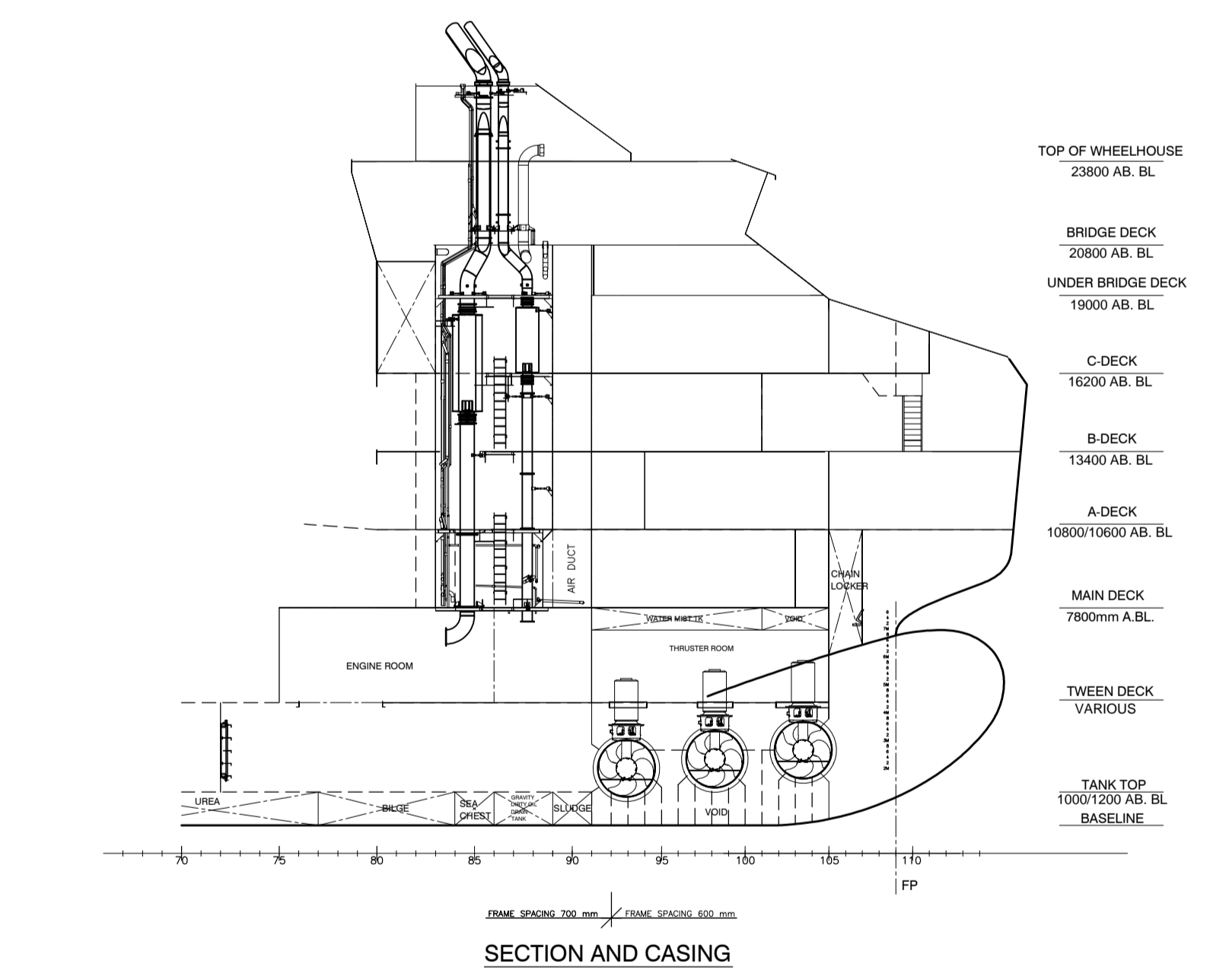
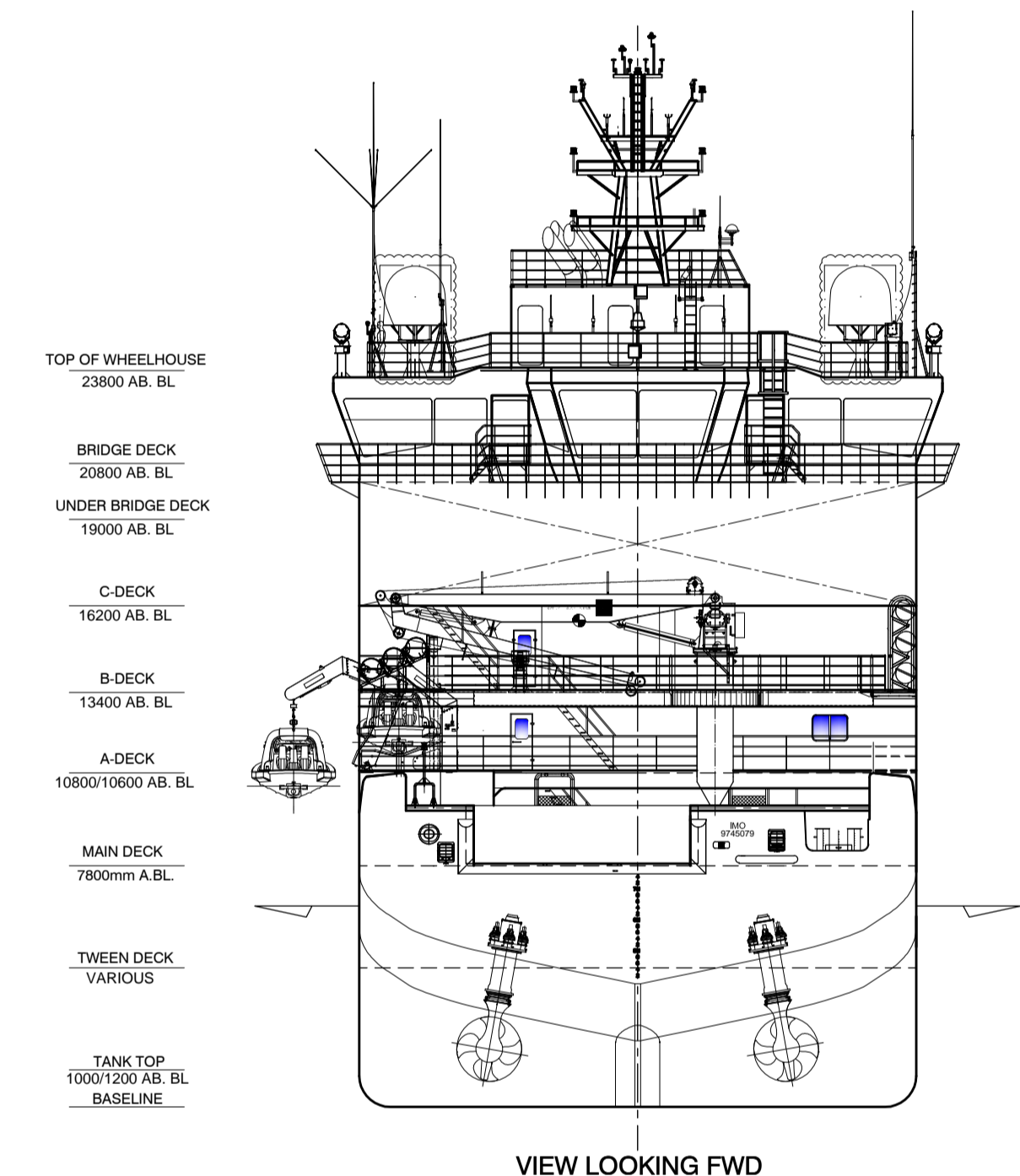
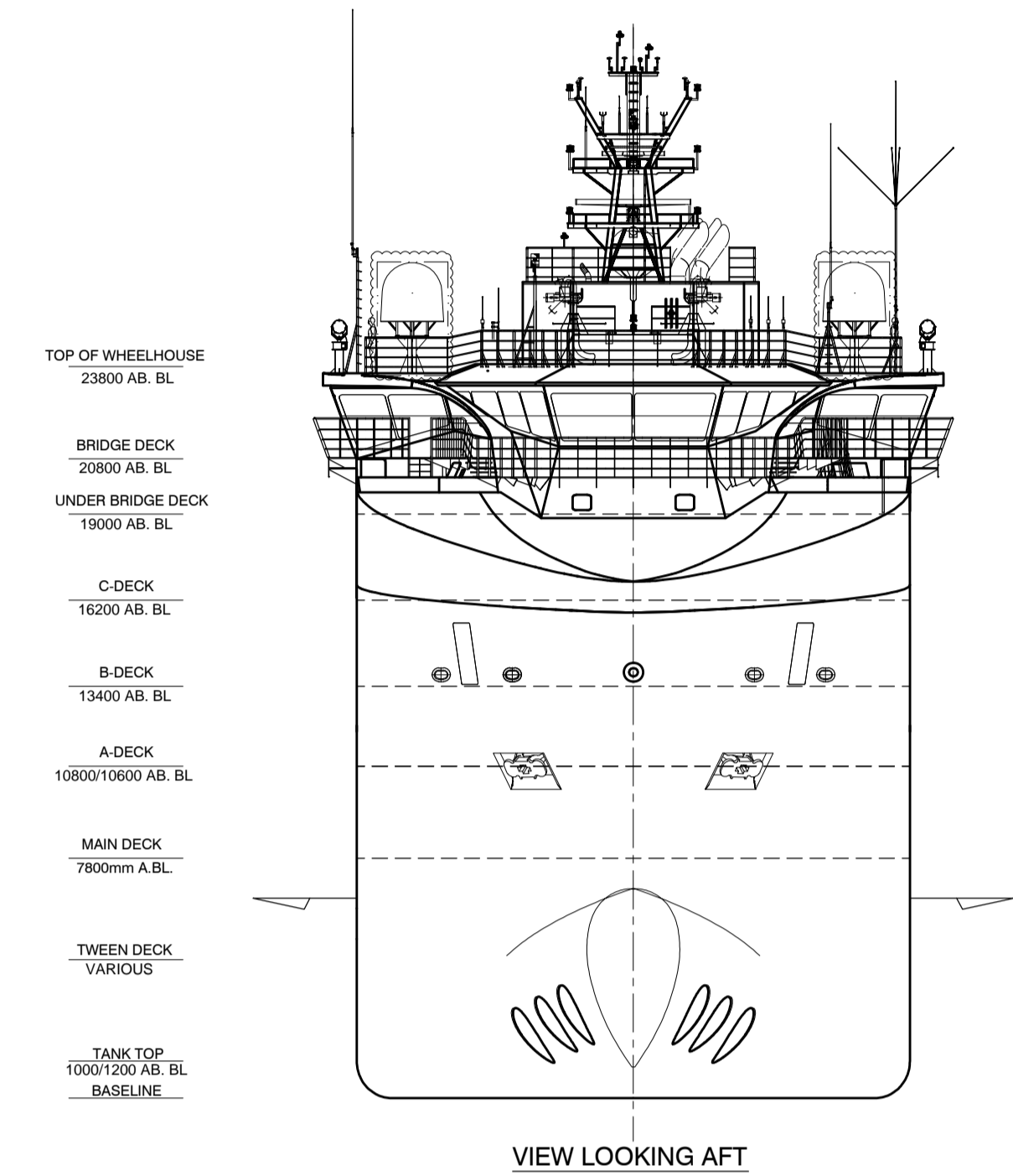
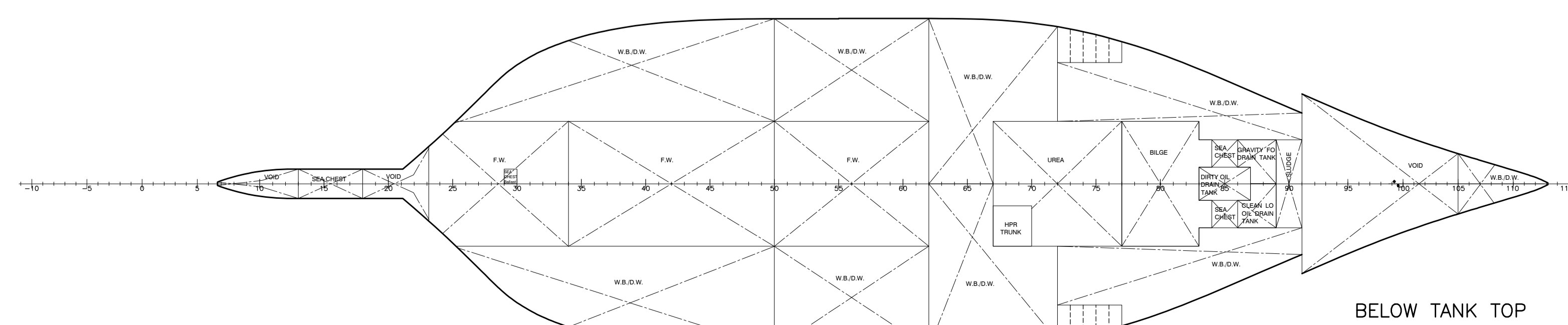
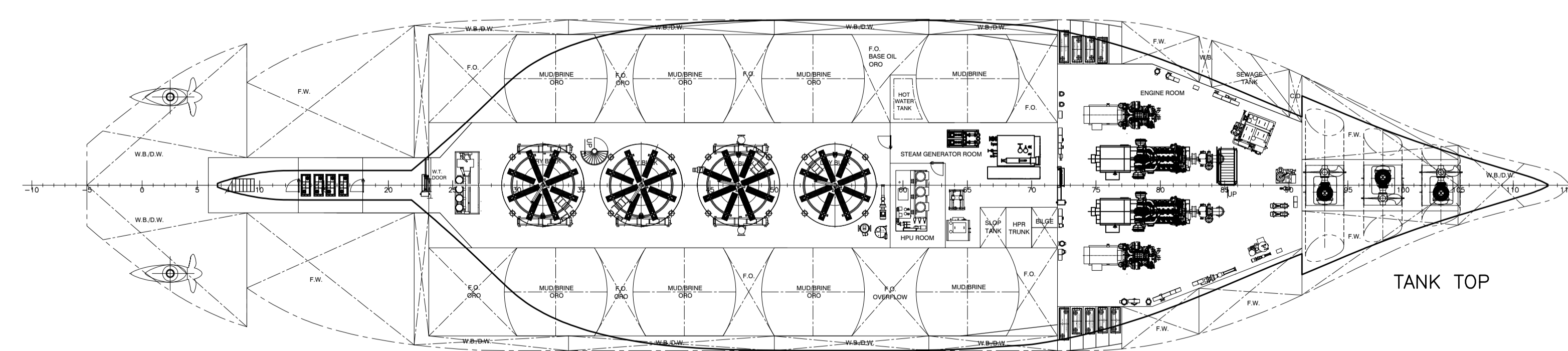
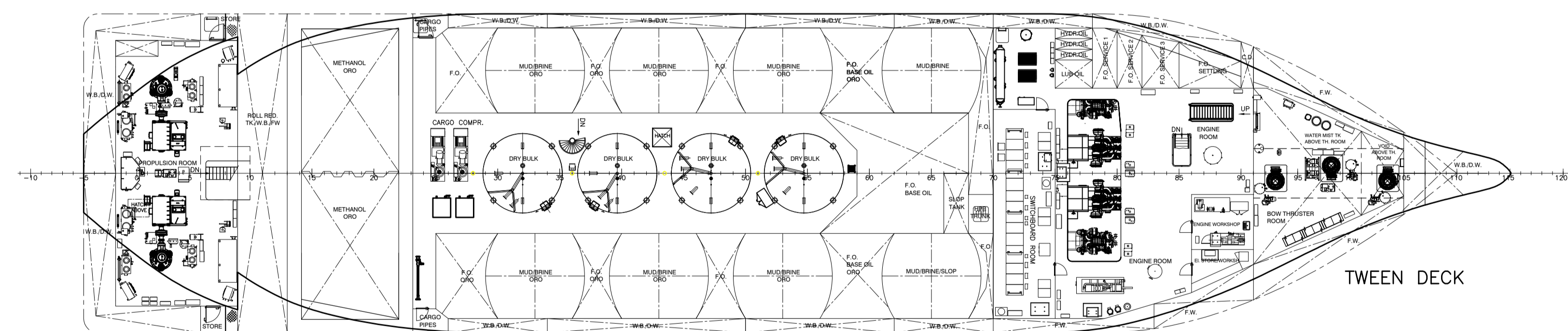
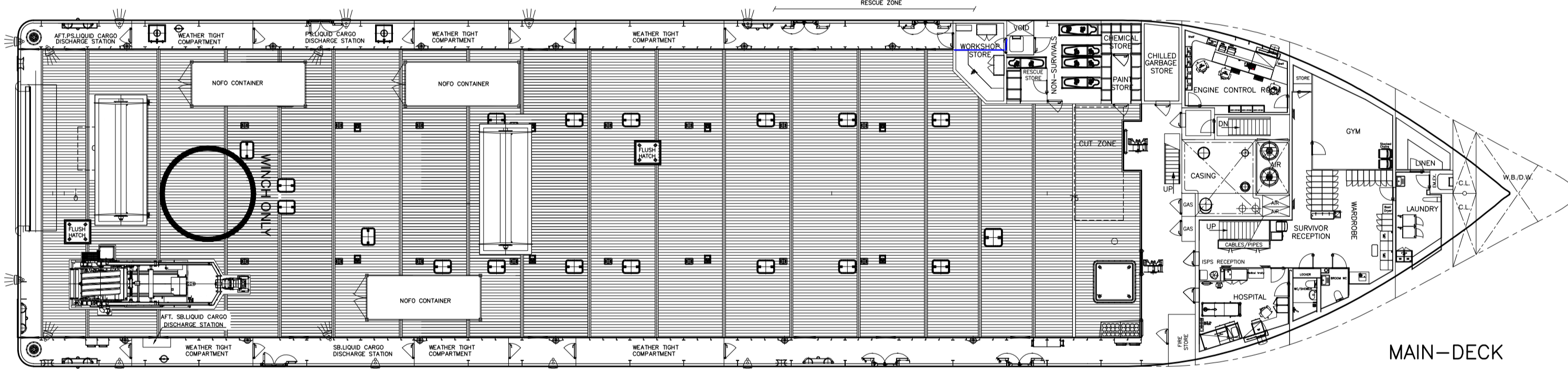
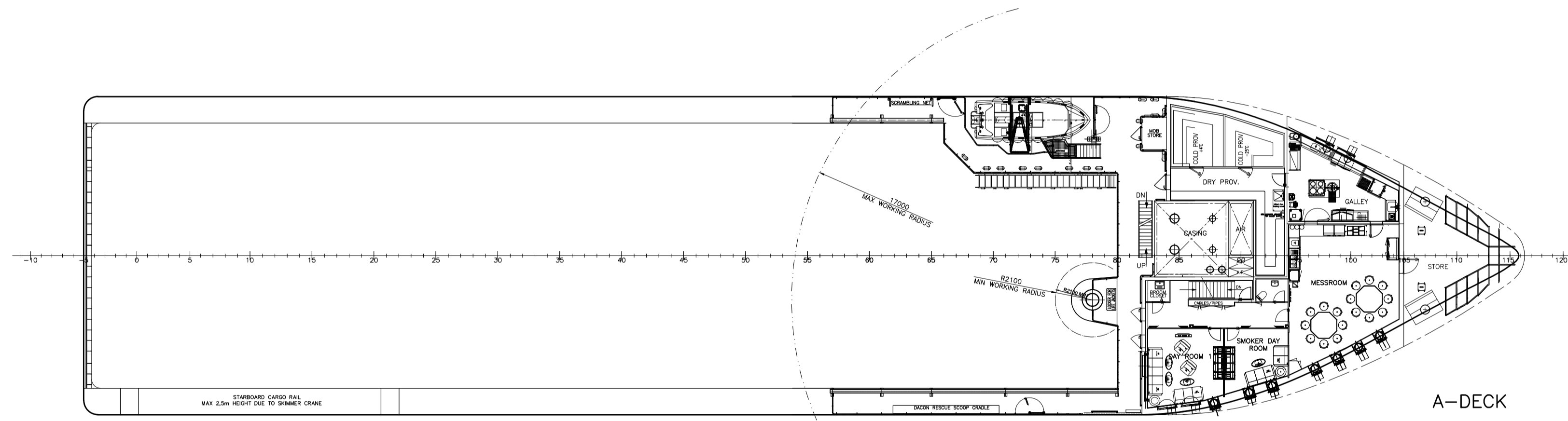
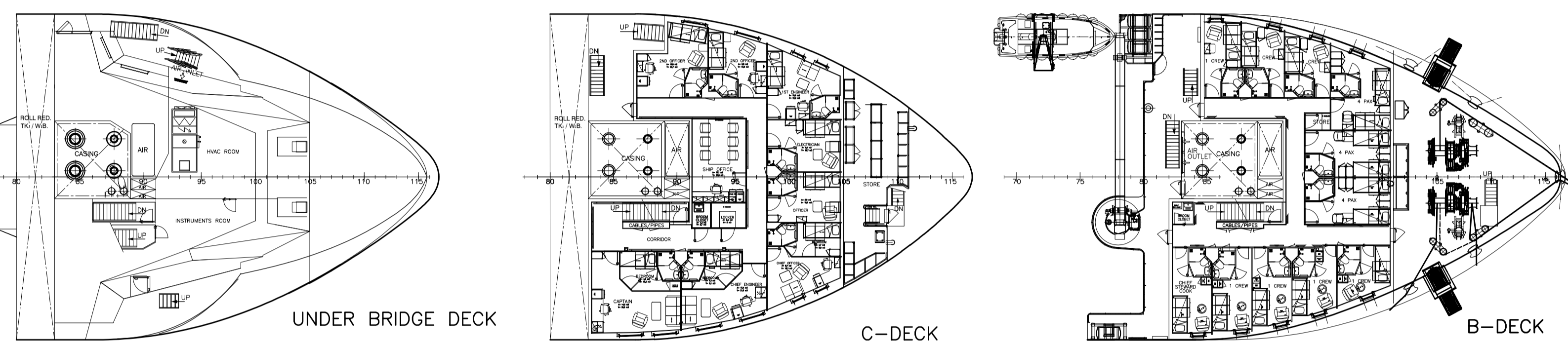
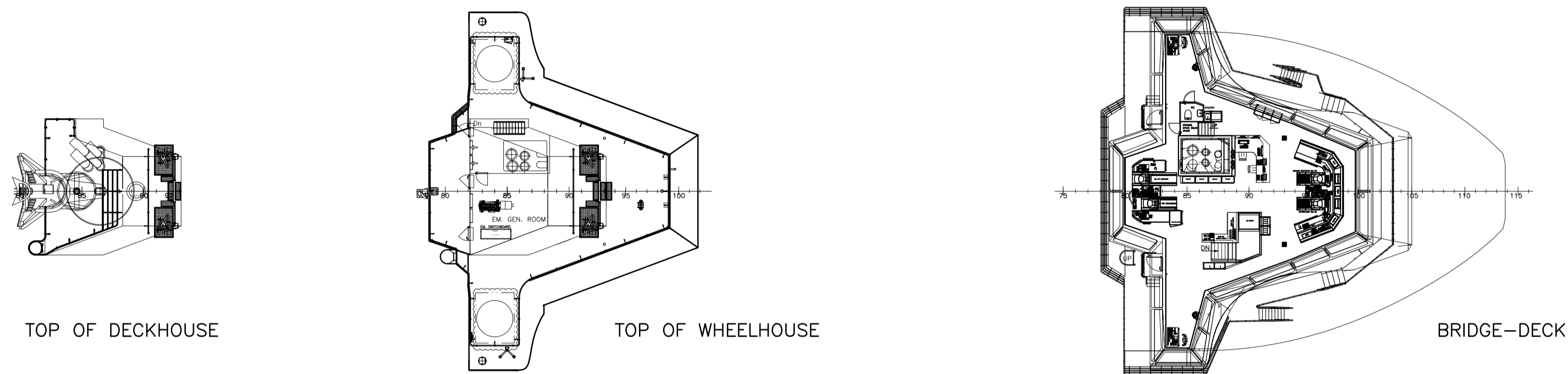
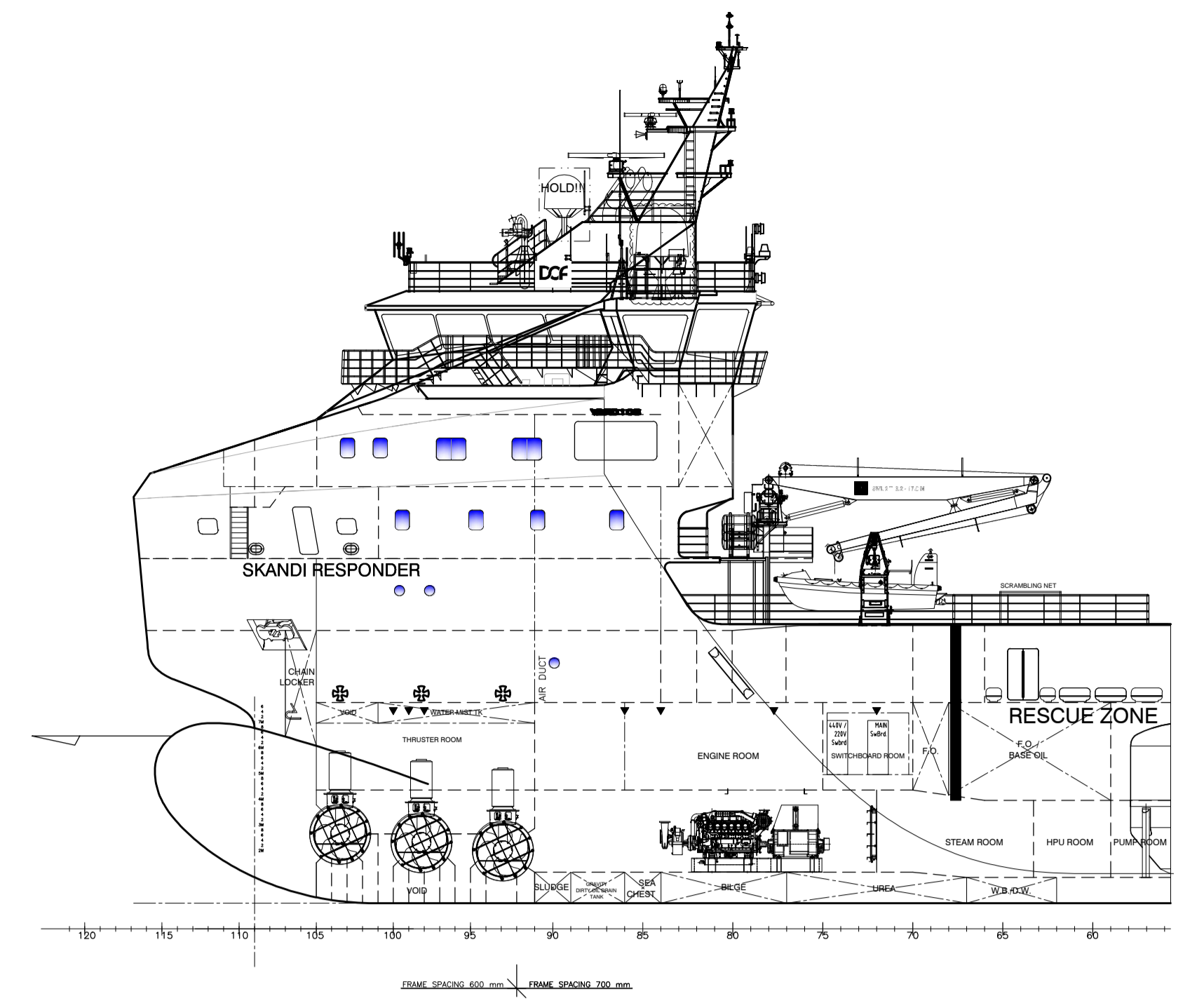

VARD 1 08

MAIN PARTICULARS APPROX.

LOA	81.7 m
L.P.P.	74.0 m
BREADTH MLD.	18.0 m
DEPTH MAIN DK.	7.8 m
MAX. DRAUGHT	6.5 m
LIQUID MUD / BRINE	1 250 m ³
DRY BULK	300 m ³
METHANOL	200 m ³
FUEL OIL	900 m ³
FRESH WATER	775 m ³
WATER BALLAST / DRILL WATER	1 800 m ³
ORO	1 500 m ³
BASE OIL	300 m ³
DECK CARGO (G=1m above dk.)	2 200 t
CARGO DECK AREA	830 m ²
DEADWEIGHT	4 100 t
ACCOMMODATION:	
SINGLE CASINS	16 PERSONS
DOUBLE CASINS	12 PERSONS
TOTAL	28 PERSONS

CLASSIFICATION AND NOTATIONS:
DNV r1A1, Offshore Service Vessel, SF, E0, DYNPOS-AUTR, DK(+), HL (2.8), CLEAN DESIGN, NAUT-OSV(A), COMF-V(3), Fire Fighter I, OILREC, Standby Vessel, LFL*, ICE-C

NMD Rescue for 200 persons, NOFO 2009

REV.	DATE	TEXT	SCALE	DRW. NO.	TITLE
C	15.09.15	Update Visor			
B	09.09.15	Update stern gate and vessel name			
A	18.06.15	See revision_A list			
D	22.05.14	REF. TO 791-101-001_B			
1 of 1					
DATE	22.08.2014	SCALE	1:200	PROJECT	808-101-001 C
DATE	22.08.2014	SCALE		PROJECT	
DATE	22.08.2014	SCALE		PROJECT	
				Vard Design AS P.O. Box 75 NO-8001 Ålesund Norway Tel: +47 70 21 06 00 www.vard.com	
VARD 108 GENERAL ARRANGEMENT				TITLE VARD 108 GENERAL ARRANGEMENT	
SHEET A0				NO. 1311	
DRAWN BY VARD 108				CHECKED BY VARD 108	